

## 1. Introduction

# Easy Roller Module

## Versatile Robot Wheel Mounting System

### Features

- ◆ 12V – 200RPM – 3.6KG•CM torque DC gearhead motor
- ◆ High traction neoprene foam wheel
- ◆ Sturdy aluminum wheel mount
- ◆ Mounting hardware included

### 1.1 Description

The Easy Roller Module was designed to simplify mechanical mounting requirements for small robotic projects. This product replaces mechanical mounting systems with a dependable solid structure and provides an easy-to-implement method of engineering a skid-steering drive system.

When used in conjunction with the Motor Mind C a complete skid-steering drive control system may be rapidly implemented.

### 1.2 Parts List

If you purchased an Easy Roller Module your product should have been shipped with the following hardware and components. If you are missing components and you purchased the product from Solutions Cubed call Solutions Cubed immediately and request the missing components. If you purchased your product from one of our distributors please return your product to the distributor.

Item Number	Quantity	Part Reference	Description
1	1	MM-HN-REV3	aluminum motor mount
2	1	M12V200	12V gearhead Motor
3	4	B1, B2, B3, B4	6-32 x 5/8" machine screw - UNC
4	4	N1, N2, N3, N4	6-32 hex nut - UNC
5	4	W1, W2, W3, W4	#6 split lock washer
6	4	W5, W6, W7, W8	#6 flat washer
7	4	B5, B6, B7, B8	M3-0.5 x 8mm screw
8	4	W9, W10, W11, W12	M3-0.5 lock washer
9	4	B9, B10, B11, B12	5-40 x 1/2" socket head screw – UNC
10	1	SS1	10-32 x 1/4" set screw – UNF
11	1	WHL1	neoprene foam tire 2.5"D x 2.0"W
12	1	HUB1	Nylon 5-40 wheel hub
13	1	TOOL1	L-shaped hex key (allen# 57012)

## 2. Easy Roller Specifications and Assembly

### 2.1 DC Gearhead Motor Characteristics

Characteristic	Value	Unit
<b>M12V200</b>		
Operating voltage	4.5-12	V
No load current	111	mA
No load speed	200	RPM
Startup torque	3.6	KG•CM
Gear ratio	30:1	

### 2.2 Neoprene Wheel Dimensions

Characteristic	Value	Unit
<b>WHL1</b>		
Wheel width	2.0	Inch
Wheel diameter	2.5	Inch
Color	Black	
Material	Foam	
Mounting screws x4	5-40	

### 2.3 Mechanical Dimensions

All dimensions listed below are in mils (0.001 inches).

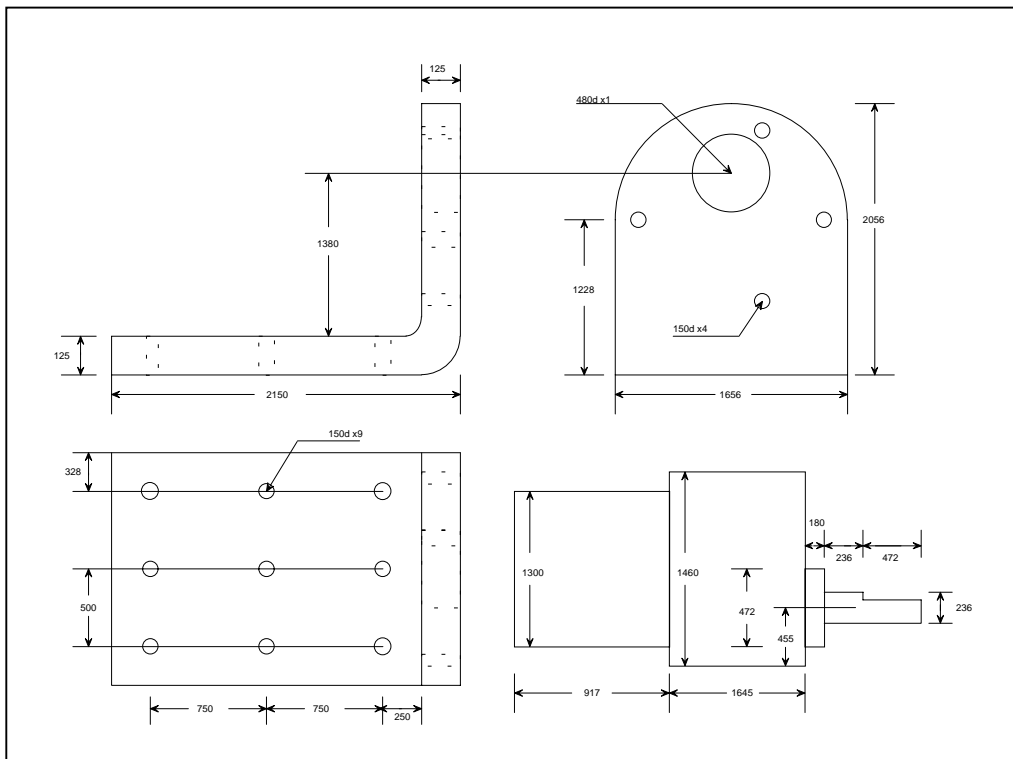

## 2.4 Assembly Instructions

**STEP1:** Drill four mounting holes in your robot chassis using the aluminum motor mount as a template for marking the holes. The holes should be large enough to fit the 6-32 x5/8" machine screws. Then apply the mounting hardware as shown in the diagram below. A minimum of four mounting screws should be applied.

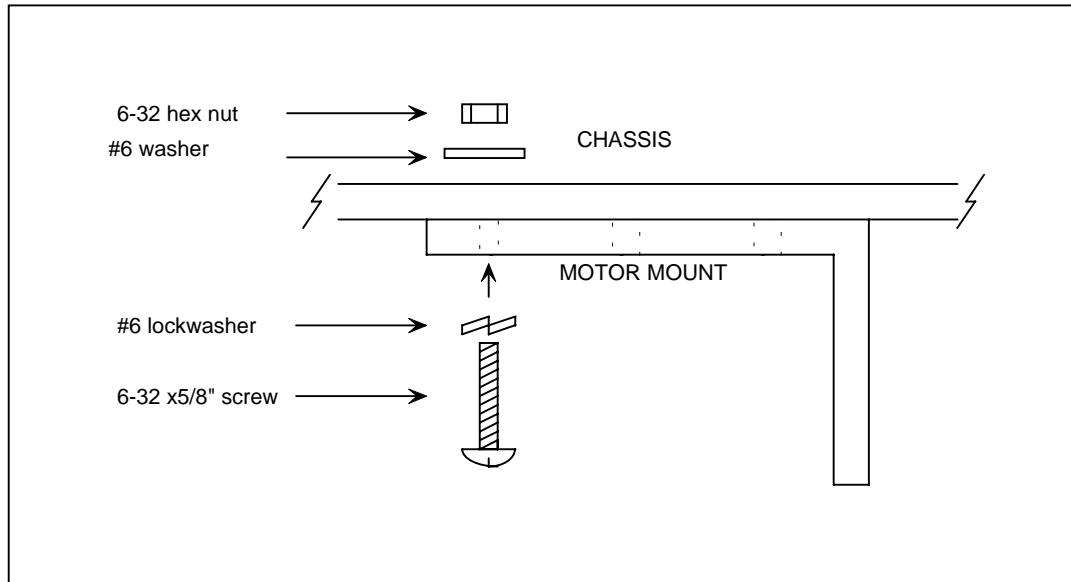

**STEP2:** Mount the DC gearhead motor to the aluminum motor mount. Rotate the motor so that all four mounting holes can be seen through the holes in the face of the motor mount. Apply the M3-0.5 x 8mm screws and lockwashers. All four motor mount screws should be applied.

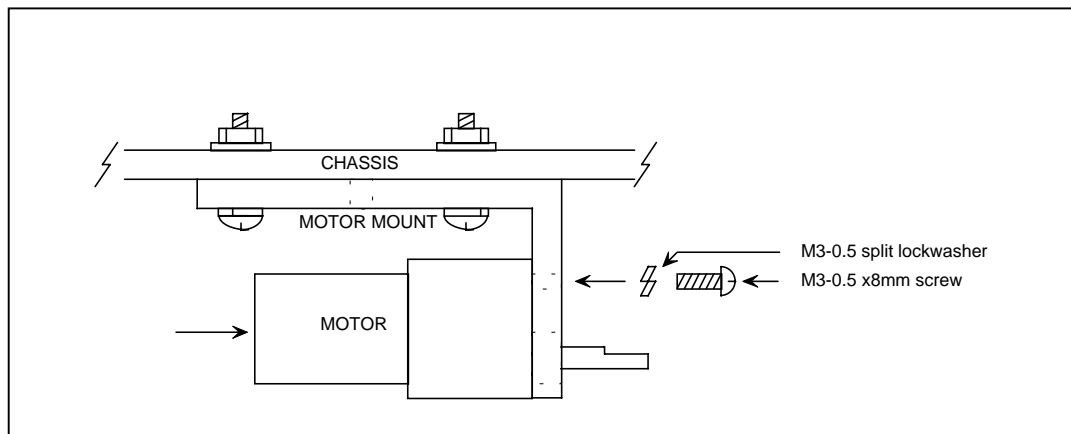

**STEP3:** Apply the nylon wheel hub to the shaft of the motor. Use the “L” shaped Allen wrench to tighten the set screw against the flat of the motor shaft. The set screw is 10-32 fine, self-locking. The Allen wrench required to tighten the set screw is 3-32 and has been included with your kit.

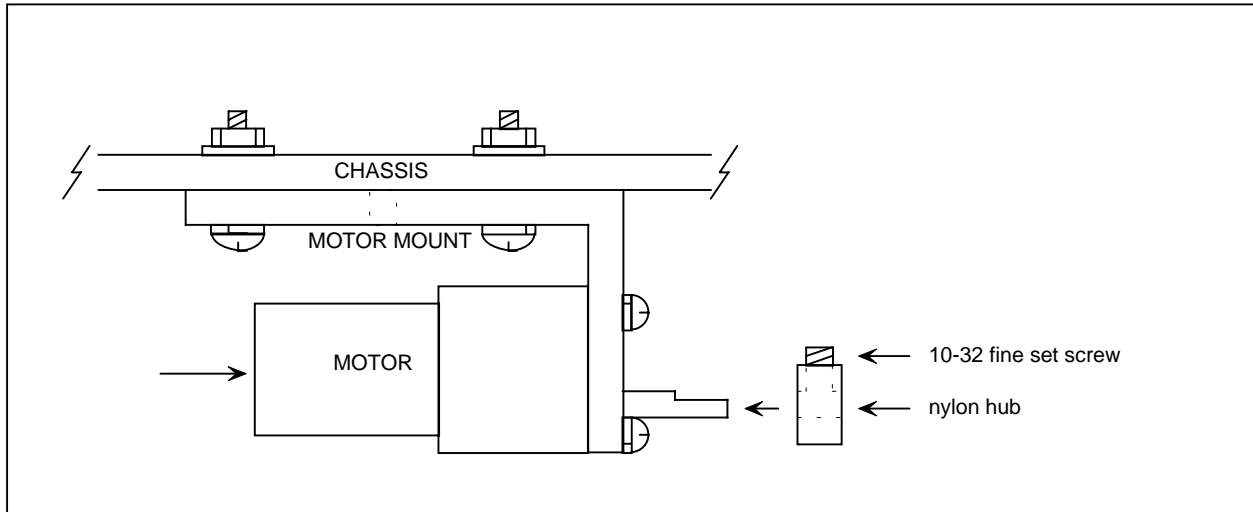

**STEP4:** Mount the wheel onto the nylon hub with four 5-40 x 1/2" socket head screws. Avoid cross threading the nylon hub. Also, do not over-tighten the socket head screws, as you will strip the nylon.

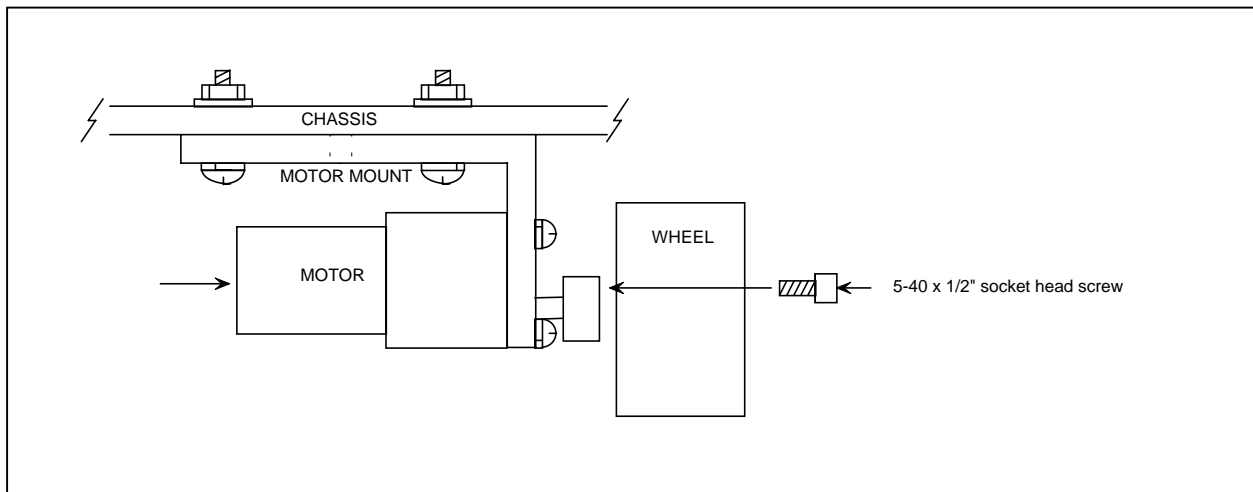

**Disclaimer of Liability and Accuracy:** Information provided by Solutions Cubed is believed to be accurate and reliable. However, Solutions Cubed assumes no responsibility for inaccuracies or omissions. Solutions Cubed assumes no responsibility for the use of this information and all use of such information shall be entirely at the user's own risk.

**Life Support Policy:** Solutions Cubed does not authorize any Solutions Cubed product for use in life support devices and/or systems without express written approval from Solutions Cubed.

**Warranty:** Solutions Cubed warrants all Easy Roller Modules against defects in materials and workmanship for a period of 90 days. If you discover a defect, we will, at our option, repair or replace your product or refund your purchase price. This warranty does not cover products that have been physically abused or misused in any way.

