

DMX- 4 Channel LED Driver Board, Part # 1-573



The DMX-LED driver board allows up to 4 LED arrays to be driven and controlled directly from a DMX512 network. The board provides 4 output channels of PWM running at 2kHz and also incorporates the ability to drive a standard Unipolar stepper motor. The base address may be set anywhere between 1 and 509.

Connections:

DMX : Dual 3-pin terminal connections

Power: Dual Ganged Terminal connections 0/12V, Board power requirements are 9-12V DC at 0.5 Amps + LEDs load current: Maximum 8 amps if using terminal connectors as Figure 1

Outputs: 4 +/- voltage outputs via screw terminals at up to 5 amps per channel @ 24 Vdc if wired as Figure 2

Command Syntax:

The DMX-PWM board may be set to operate in the LED (PWM) mode (DIP switch #10 set to OFF) or Stepper motor drive mode (DIP switch #10 set to ON)

LED (PWM) mode:

The value in the base address channel controls the PWM stream on channel 1 a DMX value of 0 will switch the load permanently OFF and a value of 255 will switch the load permanently ON. 128 will generate a 50% duty PWM signal running at 2kHz. The resolution of the PWM stream is 8-bit.

The value of the base address+1 channel controls output channel 2 etc

The PWM signal is suspended if a valid DMX signal is not being received.

Stepper Motor Drive Mode:

The 4 outputs are configured to drive a standard Unipolar Stepper motor figure 3. The direction and motor speed are controlled by the value on the DMX base address channel. For value greater than 128, the motor rotates in the clockwise direction a value of 129 produces the slowest rotation at 128msecs per step and 255 produces the fastest rotation speed of 0.5msecs per step.

For values less than 128, the motor will rotate in the anticlockwise direction a value of 127 produces the slowest rotation speed at 128msecs per step and 0 produces the fastest rotation speed of 0.5msecs per step.

For the outputs to be energised, the value on the base address+1 channel must be greater than 128 also.

Stepping is suspended if no valid DMX signal is recognised.

Base Address Selection:

The base address may be set between 1 and 509 using the DIP switches. Calculate the setting by adding the value of the switches that are set to the ON position.

The Base Address is continuously read.

The Base address may be set between 1 and 509

Addresses greater than 509 are treated as being 509

Address 0 is treated as being 1.

Outputs:

The 4 output channels are rated at 5 Amps/ 24VDC and are arranged as open collector devices.

PWM (LED) mode:

The LEDs should be wired in common anode format to the "+" input and the cathodes routed via a suitable current limiting resistor to the relevant "-" input on the board **Figure 1**.

N.B. Max 2 amps per channel @ 12Vdc, If LED strings require 24Vdc or >2 amps per channel connect as Figure 2.

Stepper Motor Drive mode:

The Unipolar motor windings should be connected as shown in **Figure 3**. The centre connection of both windings should be connected to the **+12/24 Vdc** supply and the ends of the windings connected to the driver output "-" terminals.

N.B. Maximum motor coil current 2.5 amps per winding.

Indicators:

Power LED

Correct power applied

DMX Status LED

Valid DMX signal being received- solid red LED. No DMX signal, flashing red LED.

Mechanical:

PCB size: 112mmx70mm.

Connection diagrams:

Figure 1: 4 x LED Strips 12V Dc @ 2 Amps Per Channel Max

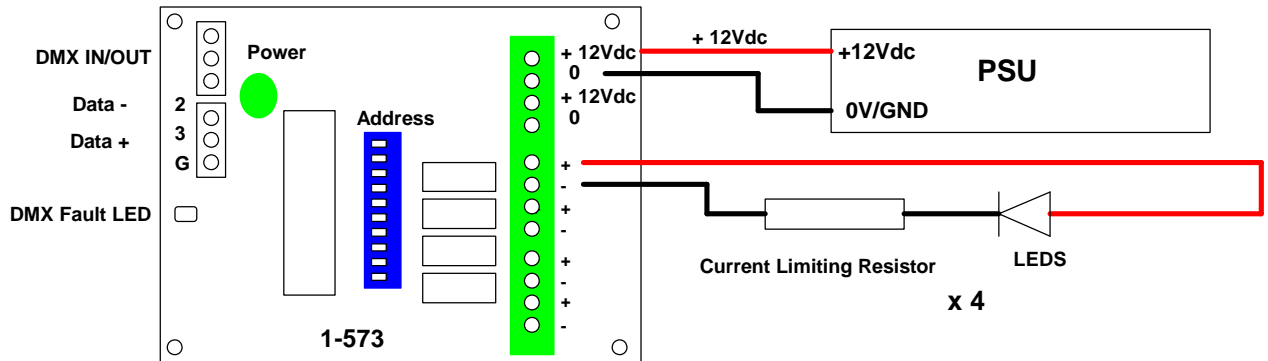

Figure 2: 4 x LED Strips 12/24V Dc @ 5 Amps per Channel Max

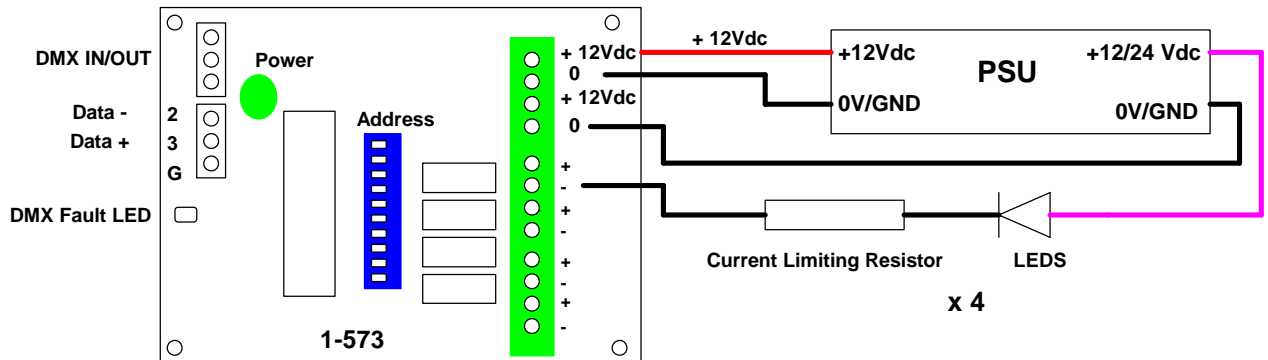

Figure 3: Unipolar Stepper Motor @ 12/24Vdc @2.5 Amps Max

